

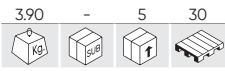

KAROSSERIEWERKSTATT 2026

53224

142,00€



AUSBEUL WERKZEUG SET - 32 TEILE



ERSATZTEILE VERFÜGBAR



x5	ZUGADAPTER FÜR DELLENLIFTER, 5ER SET - BLAU (IN SET REF. 53224)
x5	ZUGADAPTER FÜR DELLENLIFTER, 5ER SET - GELB (IN SET REF. 53224)
x10	ZUGADAPTER FÜR DELLENLIFTER, 5ER SET - ROT (IN SET REF. 53224)
x5	SET MIT 5 KLEBSTOFF-STANGEN (SET IN REF. 53224)

52876

182,00€



KAROSSERIEWERKZEUG SET - 7 TEILE



ERSATZTEILE VERFÜGBAR



x1	HANDBAUST MIT FLACHE UND OVALE FLÄCHE
x1	HANDAMBOSS - KUNSTSTOFFBESCHICHTUNG
x1	HANDBAUST MIT OVALE - KUNSTSTOFFBESCHICHTUNG
x1	HANDBAUST KEILFORM MIT GRIFF - KUNSTSTOFFBESCHICHTUNG
x1	KOMMAFÖRMIGE HANDBAUST - KUNSTSTOFFBESCHICHTUNG
x1	ABSATZFORM HANDBAUST - KUNSTSTOFFBESCHICHTUNG
x1	KOMMAFÖRMIGE HANDBAUST MIT GRIFF - KUNSTSTOFFBESCHICHTUNG

51131

61,00€

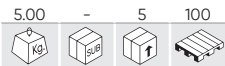

KAROSSERIE-WERKZEUG SET - 7 TEILE



ERSATZTEILE VERFÜGBAR



x1	SPANN-, AUSBEUL- UND SCHLICHTHÄMMER
x1	AUSBEUL-PINHAMMER
x1	AUSBEUL- UND SCHLICHT- SPITZHAMMER
x1	ABSATZFORM HANDBAUST
x1	KOMMAFÖRMIGE HANDBAUST
x1	HANDBAUST MIT OVALE- UND FLACHFLÄCHE
x1	HANDAMBOSS

53545

38,50€

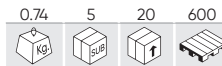

3/8" 6-KANT-SCHLAGNÜSSEN SET, EXTRALANG - 5 TEILE



x1	8mm
x1	10mm
x1	3/8" 120mmL 12mm
x1	13mm
x1	14mm



55116

125,50€

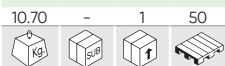

NEW

KAROSSERIE-DELLENREPARATUR-SET 11-TLG

Teile	11
Gewicht	10,50Kg
Abmessungen (LxBxH)	770x100x215mm



51832 18,00€

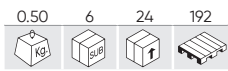

NYLON-HEBELN SET - 4 TEILE



x4	19x273mm
	22x273mm
	25x273mm
	36x273mm

50903 30,80€

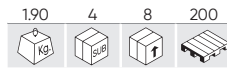

SET METALLHEBEL MIT SCHAFT - 5 TEILE



x5	180mm
	280mm
	380mm
	430mm
	600mm

52026 34,50€

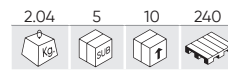

GROSSEN METALLHEBELN SET - 2 TEILE



x2	900mm
	900mm

52851 9,65€

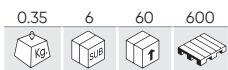

HEBEL FÜR KLAMMERN SET - 2 TEILE



x2	7x220mm
	8.5x245mm

53110 29,50€

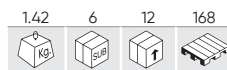

GREIFER SET - 6 TEILE



x1	4.5x240mm	x1	4.5x490mm
	8.5x240mm		8.5x490mm
	10.3x24mm		10.3x490mm

51360 8,20€

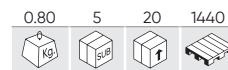

51361 12,00€

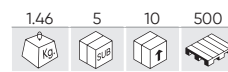

EUOPÄISCHER NAGEL-HEBENEISEN



x1	51360	18" x 5/8
	51361	24" x 3/4

50901 16,00€

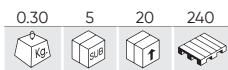

SET AUS 5 NYLON-GRIFFEN



x5	60x160, 63x175, 30x200, 20x180, 20x215mm
----	--

52788 39,00€

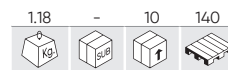

SET AUS 27 NYLON-GRIFFEN



52977

141,00€

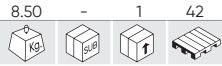

STEMMHEBEL 4ER SET EXTRALANG



Teile	4
Maßnahmen	0° 900x16mm, 30°900x16mm, 75°600x16mm, 90°600x16mm
Gewicht	8,50Kg
Abmessungen (LxBxH)	1005x260x80mm

52540

221,00€



AUSBEUL-PISTOLE MIT SAUGNAPF



Teile	5
Widerstand	7,6BAR
Durchmesser	75, 100, 125mm
Länge	620mm
Gewicht	4,36Kg
Abmessungen (LxBxH)	620x250x100mm

54017

12,00€

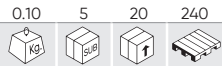

SILIKONNAHTABDICHTUNGSWERKZEUG

Enthält	Almohadillas de silicona/Silicone pads
Gewicht	0,10Kg
Abmessungen (LxBxH)	270x44x95mm

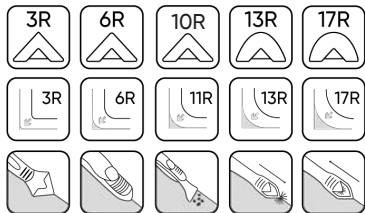

52533

10,00€

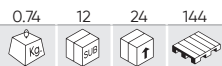

KARTUSCHEN-PISTOLE PROFI



Kapazität	300ml
Gewicht	0,74Kg
Abmessungen (LxBxH)	360x215x60mm

53567

43,00€



DRUCKLUFT KARTUSCHEN-PISTOLE 310ML



Lufteinlass	1/4"
Arbeitsdruck	2,5-5BAR
Kapazität	310ml
Gewicht	1,05Kg
Abmessungen (LxBxH)	305x185x65mm

60032

123,00€

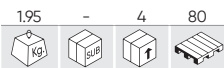

AKKU-KARTUSCHENPRESSE

Spannung	20V
Maximale Schubkraft	2500N
Vorschubgeschwindigkeit	0,5-8 mm/s (30-480mm/min)
Patronenkapazität	300ml
Geschwindigkeit	Ajustable/Adjustable
LED	Si/Yes
Kompatibel mit	60012, 60013, 60015, 60016, 60017
Gewicht	1,60Kg
Abmessungen (LxBxH)	420x70x270mm



ERSATZTEILE VERFÜGBAR

60032C

266,00€

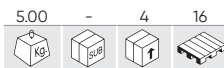

AKKU-KARTUSCHENPRESSE MIT KOFFER

Spannung	20V
Maximale Schubkraft	2500N
Vorschubgeschwindigkeit	0,5-8mm/s (30-480mm/min)
Patronenkapazität	300ml
Geschwindigkeit	Ajustable/Adjustable
Beinhaltet	60032, 60013, 60016
LED	Si/Yes
Kompatibel mit	60012, 60013, 60015, 60016, 60017
Gewicht	4,96Kg
Abmessungen (LxBxH)	500x130x400mm



ERSATZTEILE VERFÜGBAR

53525

12,00€

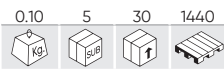

FESTSTELLKRALLE FÜR GASFEDERN



Durchmesser	10mm
Gewicht	0,10Kg
Abmessungen (LxBxH)	140x90x30mm

53655

12,00€

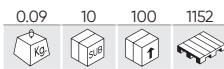

ABZIEHER FÜR TÜRGRIFFE VAG



Marken	VAG
Gewicht	0,09Kg
Abmessungen (LxBxH)	340x70x40mm

54246

104,00€

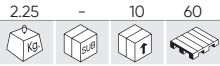

5 KG PRÄZISIONSWAAGE



Kapazität	5Kg
Präzision	0,1g
Messung der Wechselfspannung (AC)	220V
Messung der Gleichspannung (DC)	6V
Arbeitstemperatur	0-40°C
Relative Luftfeuchtigkeit	10%<RH<85%
Gewicht	2,25Kg
Abmessungen (LxBxH)	280x115x285mm

54247

99,00€



2 KG PRÄZISIONSWAAGE



Kapazität	2Kg
Präzision	0,1g
Messung der Wechselfspannung (AC)	220V
Messung der Gleichspannung (DC)	6V
Arbeitstemperatur	0-40°C
Relative Luftfeuchtigkeit	10%<RH<85%
Gewicht	2,25Kg
Abmessungen (LxBxH)	352x136x240mm

53230

20,50€

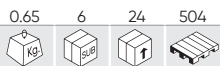

AUFSPERRHILFE SET

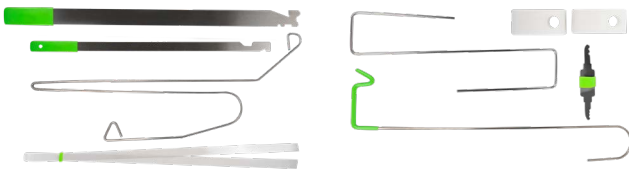

- x2 Öffnungsband für Griffe
- x2 Nylon Keil mit Mittelloch
- x1 Starrer Haken in Form von "s"
- x1 Schiebehaken zum Entriegeln von Sicherungen
- x1 Breiter Entriegelungshebel 610mm
- x1 558mm schmaler Verriegelungshebel
- x1 Schlüssel Typ Granzúa für Schlösser
- x1 Spezieller Haken

52077

29,50€



LUFTKISSEN SET - 4 TEILE



- x1 Kissen 16 x 16 cm
- x1 Kissen 32 x 12 cm
- x1 Kissen 19 x 6 cm
- x1 Kissen 18 x 4,5 cm
- x1 Handpumpe

53486

30,50€



STREIFENSEGEL ZUM ERKENNEN VON DELLEN

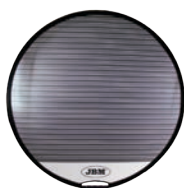

Durchmesser	800mm
Gewicht	0,30Kg
Abmessungen (LxBxH)	320x300x40mm

15375

28,00€

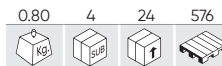

FLÜSSIGPOLYMER FÜR REF. 53673



Kapazität	600ml
Gewicht	0,80Kg
Abmessungen (LxBxH)	75x75x190mm

53673 **80,00€**

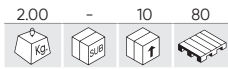

SCHEINWERFER-WIEDERHERSTELLUNG SET

x6	6 SCHMIRGELBLÄTTER FÜR REF.53673
x1	KABELSTROM-ADAPTER FÜR REF.-NR. 53673
x1	ADAPTER 12 V FÜR REF.-NR. 53673
x1	SPRÜHBECHER REF.-NR. 53673
x1	GEBOGENER DECKEL MIT O-RING FÜR REF. 53673
x1	FLACHER DECKEL MIT O-RING FÜR REF. 53673
x1	TRICHTER FÜR REF.-NR. 53673
x1	SCHLEIFPLATTE FÜR REF. 53673
x1	MALER-TAPE FÜR REF. 53673
x1	FLÜSSIGPOLYMER FÜR REF. 53673



SATZ VON 10 ELEMENTEN SCHLEIFPAPIER

REF.	KÖRNUNG	KG	L	€
14710	180	0.25	10	3,90€
14711	280	0.20	10	4,00€
14712	360	0.20	10	4,00€

REF.	KÖRNUNG	KG	L	€
14713	600	0.15	10	4,25€
14714	800	0.15	10	4,50€
14715	1200	0.10	10	4,75€



VIDEO-TUTORIAL



ERSATZTEILE VERFÜGBAR

52740 **690,00€**

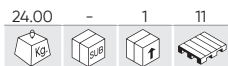

SCHEINWERFER EINSTELLGERÄT MIT LUXMETER



Minimale Hubhöhe	230mm
Maximale Hubhöhe	1350mm
Messung	LUX Digital
Kompatibel mit	Hálogeno/Xenón
Gewicht	24,00Kg
Abmessungen (LxBxH)	520x280x1520mm

52836 **1.100,00€**

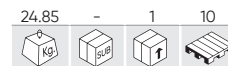

SCHEINWERFER EINSTELLGREÄT MIT DOPPEL-LASER UND LUXMETER



VIDEO-TUTORIAL

Minimale Hubhöhe	230mm
Maximale Hubhöhe	1350mm
Messung	Láser/Láser, LUX Digital
Kompatibel mit	Cualquier tipo de faro/Any type of car lighthouse
Gewicht	24,85Kg
Abmessungen (LxBxH)	520x270x1560mm

53626

18,00€

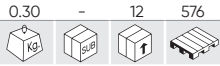

SCHEINWERFER-POLIER SET

- x2 P800 Schleifscheiben
- x2 P1200 Schleifscheiben
- x2 P2000 Schleifscheiben
- x2 3,0 ml UV-Schutzflüssigkeit
- x2 Adapter (3/8" und 1/4")
- x1 85 g Polierpaste
- x1 Klebeband
- x1 Wollpolierscheibe
- x1 weiße Schwammscheibe



AUSSTELLER MIT 12 STÜCK

53729

20,50€

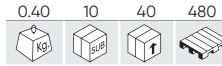

SCHRAUBERZIEHER LANG - EINSTELLUNG VON SCHEINWERFERN

- x1 H6
- x1 300mm H7
- x1 T25



SAUGNAPF

52262

7,50€

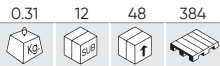

Teile	1
Durchmesser	115mm
Kapazität	40,00Kg

52263

13,50€

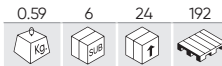

Teile	1
Durchmesser	115mm
Kapazität	70,00Kg

52264

21,50€

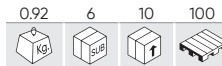

Teile	1
Durchmesser	115mm
Kapazität	100,00Kg

52265

30,50€

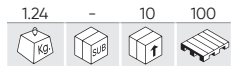

Teile	1
Durchmesser	115mm
Kapazität	120,00Kg

52295

7,00€

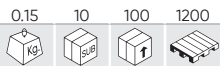

Teile	2
Durchmesser	60mm
Kapazität	5,00Kg

52589

13,00€

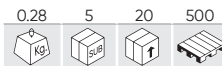

Teile	1
Durchmesser	70mm
Kapazität	8,00Kg

52765

21,70€

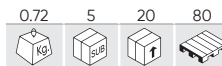

Teile	1
Durchmesser	120mm
Kapazität	80,00Kg

52998

48,00€

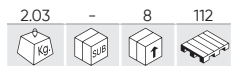

Teile	3
Durchmesser	120mm
Kapazität	80,00Kg

53232 **39,50€**

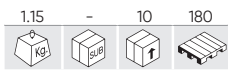

WINDSCHUTZSCHEIBE AUSTAUSCH-WERKZEUG

- x1 WERKZEUG ZUM ENTFERNEN DER WINDSCHUTZSCHEIBE
- x1 WERKZEUG ZUM ENTFERNEN DER WINDSCHUTZSCHEIBENLEISTE
- x1 WERKZEUG ZUM ENTFERNEN VON VERBINDUNGSELEMENTE DER POLSTERBESCHLÄGE
- x1 1,8 M DRAHT
- x2 HANDGRIFF ZUM GREIFEN DES DRAHTES
- x1 DRAHTVORSCHUBWERKZEUG



REF.	BESCHREIBUNG					€
13813	WINDSCHUTZSCHEIBE ENTFERNUNGS-DRAHT	0.10	10	60	1200	7,00€
13814	WINDSCHUTZSCHEIBE ENTFERNUNGS-WERKZEUG	0.20	10	60	1080	11,00€

55012 **680,00€**

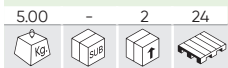

NEW

WINDSHUTZSCHEIBEN-AUSTAUSCH-WERKZEUGSATZ MIT KOFFER

- x1 ANKER DER SCHNEIDLINIE
- x1 UMLENKROLLE DER SCHNEIDLINIE
- x1 AUFWICKLER DER SCHNEIDLINIE
- x1 SYNTHETISCHES FASERKABEL L:100M
- x1 DURCHSTICHWERKZEUG
- x1 STANGE ZUR MEISSELMONTAGE
- x1 HAKENWERKZEUG 90° SPITZ
- x1 RATSCHENSCHLÜSSEL MIT 1/4"-STECKNUSS
- x1 SCHUTZPLATTE



ERSATZTEILE VERFÜGBAR



52321 **8,80€**

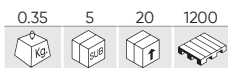

RATSCHENGURT 5M X 25MM



Teile	2
Länge	5m
Kapazität	800Kg
Gewicht	0,35Kg
Abmessungen (LxBxH)	125x115x30mm

52327 **12,00€**

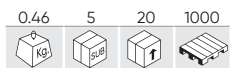

RATSCHENGURT 8M X 25MM



Teile	2
Länge	8m
Kapazität	800Kg
Gewicht	0,46Kg
Abmessungen (LxBxH)	150x140x40mm

50577 **12,60€**

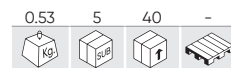

GRIPZANGE



Länge	280mm
Gewicht	0,53Kg

52385

268,00€

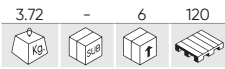

GRIPZANGEN SET - 6 TEILE



W (195mm) JJ (195mm) LL (195mm) J (210mm) T (215mm) L (225mm)

52982

55,00€

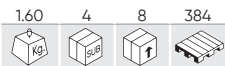

SET GRIPZANGEN EXTRALANG - 3 TEILE



Länge	90°	Länge	45°	Länge	0°
Winkel	340mm	Winkel	360mm	Winkel	370mm

53675

53,00€

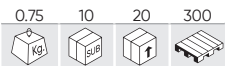

GRIPZANGE - GERADE



AUSSTELLER MIT 10 STÜCK

53676

47,00€

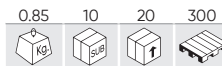

GRIPZANGE - GEBOGEN



AUSSTELLER MIT 10 STÜCK

53677

59,00€

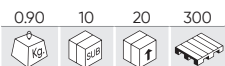

GRIPZANGE MIT SCHWENKKISSEN - GEBOGEN



AUSSTELLER MIT 10 STÜCK

53678

55,00€

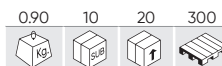





LANGE GRIPZANGE - GEBOGEN



AUSSTELLER MIT 10 STÜCK

GRIPZANGEN

REF.	BESCHREIBUNG	mm	MATERIAL		T					€
52390	SCHWEISS-GRIPZANGE SPEZIAL SCHWENKKISSEN	250mm	CrMo	-	-	0.50	5	40	640	37,50€
52474	ZUGKLEMME - RING 6T	190mm	Aus stahl	0-20mm	5T	3.49	-	5	1500	69,00€
52475	ZUGKLEMME - FLACH 3T	170mm	Aus stahl	0-25mm	3T	3.60	-	10	1500	62,00€
52476	ZUGKLEMME - RECHTECKIG 5T	220mm	Aus stahl	0-25mm	5T	3.10	-	10	1500	50,00€
52477	ZUGKLEMME -SELBSTSPANNEND 2T	200mm	Aus stahl	0-60mm	2T	2.65	-	10	1500	76,50€
52478	ZUGKLEMME - 90° 5T	170mm	Aus stahl	0-20mm	5T	2.90	-	10	1500	49,00€
52479	ZUGKLEMME - 90° MINI 3T	155mm	Aus stahl	0-20mm	3T	1.18	-	30	1500	24,70€
52480	ZUGKLEMME - 90° RECHTECKIG 3T	210mm	Aus stahl	0-25mm	3T	2.00	-	10	1500	44,00€
52481	ZUGKLEMME - RECHTECKIG 3T	220mm	Aus stahl	0-20mm	3T	2.05	-	10	1500	52,00€
52482	ZUGKLEMME - 45° FLACH 5T	210mm	Aus stahl	0-10mm	5T	2.13	-	12	1500	44,00€
52483	ZUGKLEMME - FLACH MINI 3T	210mm	Aus stahl	0-10mm	5T	2.02	-	12	1500	41,00€
52484	KETTENVERBINDER 3T	280mm	Aus stahl	0-110mm	3T	1.19	-	11	1500	70,00€
52485	HAKENVERBINDER 4T	270mm	Aus stahl	0-90mm	4T	1.17	-	30	1000	54,00€
52486	KETTE-HAKEN-VERBINDER 3T	280mm	Aus stahl	0-110mm	3T	1.21	-	11	1500	66,00€
52487	ZUGKLEMME 5T	220mm	Aus stahl	0-20mm	5T	2.27	-	7	1000	63,00€
52502	SCHWEISS-GRIPZANGE	280mm	CrMo	0-110mm	-	0.84	10	30	540	33,50€
52503	SCHWEISS-GRIPZANGE MIT SCHWENKKISSEN	280mm	CrMo	0-105mm	-	0.85	-	30	540	35,00€
52504	ZWEIBEIN-ZUGKLEMME	225mm	CrMo	0-50mm	-	1.14	-	30	480	27,60€
52505	VERSCHLUSS-GRIPZANGE	170mm	CrMo	0-40mm	-	0.27	36	72	2160	22,50€
52506	VERSCHLUSS-GRIPZANGE MIT SCHWENKKISSEN	170mm	CrMo	0-50mm	-	0.28	36	72	2160	16,00€
52507	FLACHE-GRIPZANGE	250mm	CrMo	0-80mm	-	0.77	5	30	420	32,50€
52511	SCHWEISS-GRIPZANGE 18"	440mm	CrMo	0-225mm	-	1.31	-	20	280	44,50€
52512	LANGE SCHWEISS-GRIPZANGE MIT SCHWENKKISSEN	450mm	CrMo	0-155mm	-	1.31	-	20	280	53,00€



52390



52474



52475



52476



52477



52478



52479



52480



52481



52482



52483



52484



52485



52486



52487



52502



52503



52504



52505



52506



52507



52511



52512

53983

215,00€

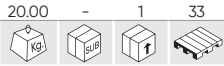

KAROSSERIE TEILEWAGEN – WINDSCHUTZSCHEIBEN UND MOTORHAUBEN



Kapazität	150Kg
Gefaltete Abmessungen	1200x120x210mm
Gewicht	19,40Kg
Abmessungen (LxBxH)	1200x700x635mm

53124

287,00€



UNIVERSALLER TELESKOP-STATIV



Kapazität	100Kg
Gefaltete Abmessungen	25x860x840mm
Gewicht	21,10Kg
Abmessungen (LxBxH)	1380x860x1300mm

53125

477,00€

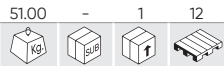

TRANSPORTWAGEN FÜR AUTOTEILE

Kapazität	150Kg
Gewicht	51,00Kg
Abmessungen (LxBxH)	900x610x1980mm



50923

454,00€

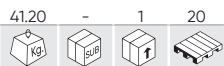

SPEZIALLER TRANSPORTWAGEN FÜR KAROSSERIEARBEITEN - FLACH 340KG



ERSATZTEILE VERFÜGBAR

Kapazität	340Kg
Eröffnung	0-1100mm
Gewicht	41,20Kg
Abmessungen (LxBxH)	1340x250x240mm

50839

198,00€



RANGIERHEBER TRAGFÄHIGKEIT 680KG



ERSATZTEILE VERFÜGBAR

Kapazität	680Kg
Eröffnung	345-660mm
Gewicht	19,20Kg
Abmessungen (LxBxH)	680x625x230mm

53079

89,00€

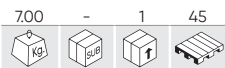

X-STANDER



Kapazität	100Kg
Gefaltete Abmessungen	660x1140x300mm
Gewicht	6,77Kg
Abmessungen (LxBxH)	600x680x870mm

53080

99,00€

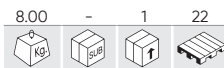

TRAGBARER STATIV FÜR WINDSCHUTZSCHEIBE



Kapazität	70Kg
Gefaltete Abmessungen	1130x285x990mm
Gewicht	7,87Kg
Abmessungen (LxBxH)	1130x610x990mm

52749

79,00€

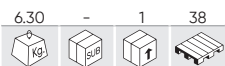

KLAPPBARER STÄNDER FÜR KAROSSERIE



ERSATZTEILE
VERFÜGBAR

Kapazität	220Kg
Gefaltete Abmessungen	1030x905x500mm
Gewicht	6,25Kg
Abmessungen (LxBxH)	1030x390x1000mm

53736

99,00€



KLAPPBARER STOSSFÄNGERSTÄNDER



Kapazität	25Kg
Gefaltete Abmessungen	600x310x1230mm
Gewicht	8,10Kg
Abmessungen (LxBxH)	600x750x1060mm

53685

310,00€

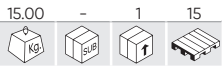

VERSTELLBARER STOSSFÄNGER STÄNDER

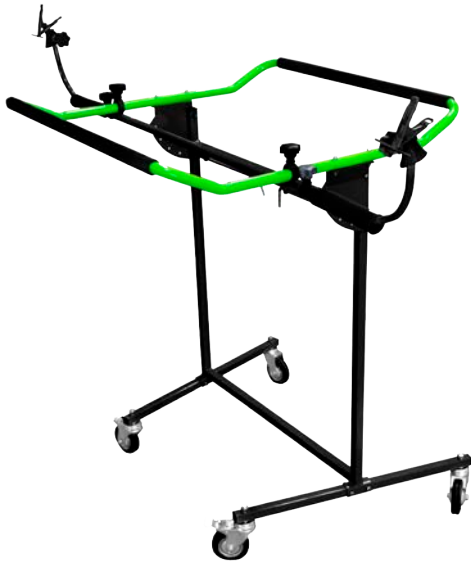

Kapazität	25Kg
Gefaltete Abmessungen	960x865x95mm
Gewicht	14,50Kg
Abmessungen (LxBxH)	762x1118x1346mm

54579

229,00€

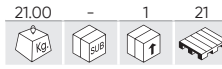

MOBILE STOSSSTANGENABLAGE



Kapazität	60Kg
Bar-Kapazität	15Kg
Gewicht	21,00Kg
Abmessungen (LxBxH)	1200x1200x2150mm

53134

145,00€

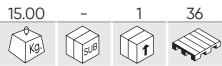

VERSTELLBARER LACKIERSTÄNDER

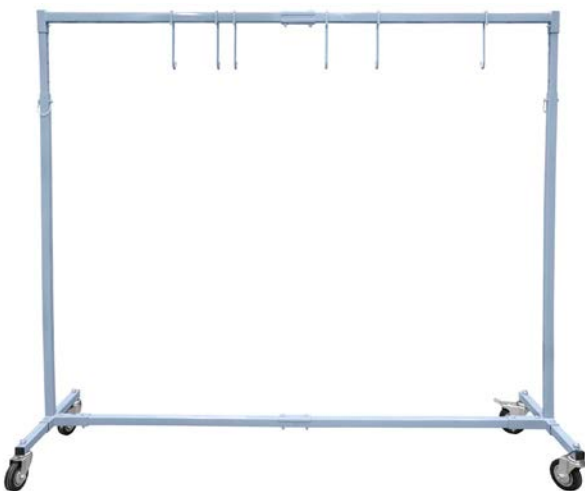

Kapazität	150Kg
Minimale Hubhöhe	1270mm
Maximale Höhe	2030mm
Enthält	6 Ganchos/Hooks
Gewicht	14,70Kg
Abmessungen (LxBxH)	1770x500x2030mm

53126

243,00€

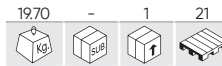

DREHGESTELL ZUM LACKIEREN



ERSATZTEILE VERFÜGBAR

Kapazität	50Kg
Enthält	6 Brazos de sujeción/Support arms
Gewicht	19,70Kg
Abmessungen (LxBxH)	1220x250x165mm

54959 **268,00€**

20.20 - 1 16 **NEW**

MOBILER LACKIERSTÄNDER FÜR FELGEN



Material	GS
Höhe	1100 - 1420mm
Drehbar	360°
Tabletts	2
Raddurchmesser	15" - 22"
Abmessungen (LxBxH)	900x670x1100mm

54960 **159,50€**

11.10 - 1 33 **NEW**

UNIVERSELLER STÄNDER FÜR KAROSERIEBLECHE UND STOßFÄNGER



Material	GS
Drehbar	90°
Maximale Belastung	100Kg
Abmessungen (LxBxH)	1220x1330x1870mm
Gewicht	10,50Kg

54961 **20,00€**

1.10 1 20 240 **NEW**

FELGENHALTER

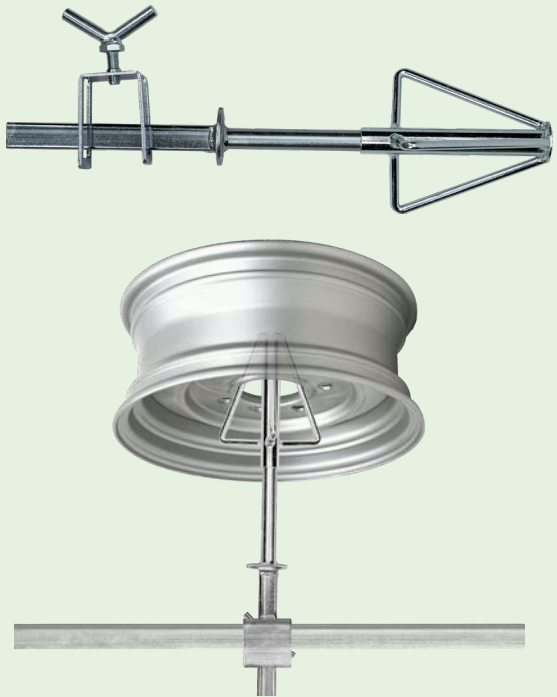

Gewicht	1,15Kg
Abmessungen (LxBxH)	130x100x380mm

54962 **430,50€**

40.25 - 1 14 **NEW**

TEILEWAGEN MIT PLATTENHALTERUNG



Maximale Belastung	120Kg
Bar-Kapazität	40Kg
Gewicht	40,00Kg
Abmessungen (LxBxH)	1220x1330x1900mm

52230

398,00€

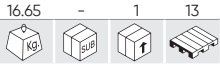

ALUMINIUM STEIGLEITER-BÜHNE, TELESKOPISCH

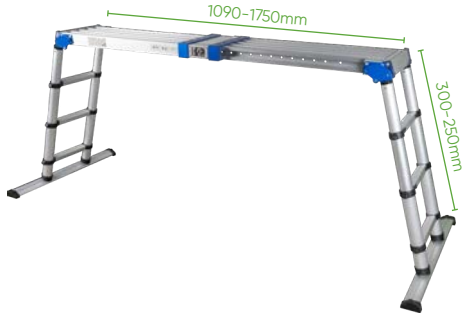

ERSATZTEILE VERFÜGBAR

Kapazität	150Kg
Gefaltete Abmessungen	300x1090x900mm
Minimale Länge	1090mm
Maximale Länge	1750mm
Minimale Höhe	550mm
Maximale Höhe	930mm
Material	Al
Konformität mit der Europäischen Richtlinie	EN131
Gewicht	16,65Kg
Abmessungen (LxBxH)	300x1750x900mm

50656

290,00€



ALUMINIUM STEIGLEITER-BÜHNE SET - 2 TEILE



ERSATZTEILE VERFÜGBAR

Kapazität	100Kg
Abmessungen der großen Plattform (LxBxH)	1300x300x550mm
Maße der zusammengeklappten großen Plattform	1300x300x140mm
Abmessungen der kleinen Plattform (LxBxH)	1000x300x300mm
Maße der zusammengeklappten kleinen Plattform	1000x300x140mm
Material	Al
Enthält	11897, 15552
Konformität mit der Europäischen Richtlinie	EN131
Gewicht	10,45Kg

50913

229,00€

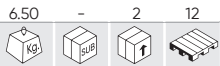

ALUMINIUM STEIGLEITER-BÜHNE



Kapazität	100Kg
Material	Al
Konformität mit der Europäischen Richtlinie	EN131
Abmessungen (LxBxH)	1400x300x800mm
Gewicht	6,50Kg
Gefaltete Abmessungen	1400x300x14mm

54789

34,00€

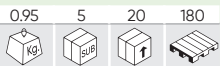

NEW

FRONTSCHUTZ FÜR AUTO



Material	Poliéster/Polyester
Gewicht	0,95Kg
Gefaltete Abmessungen	330x50x210mm
Abmessungen montiert	4050x725mm

51622

27,00€



MAGNETISCHE SCHUTZABDECKUNG LAMELLEN UND FRONTEN



Typ	Imantado/Magnetized
Material	PVC
Gewicht	0,45Kg
Abmessungen (LxH)	1300x640mm

53922

35,00€

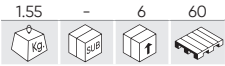

PAPIERROLLEN WANDHALTER

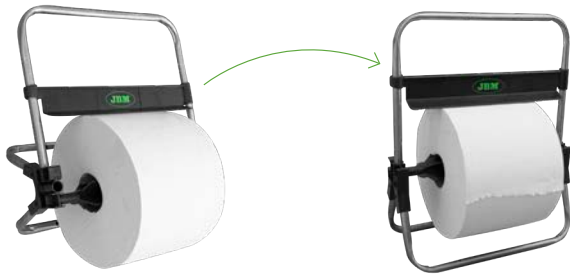

Material	Acero inoxidable/Stainless steel
Minimale Höhe	480mm
Maximale Höhe	690mm
Papierrolle	380mm
Gefaltete Abmessungen	450x270x480mm
Gewicht	1,55Kg
Abmessungen (LxBxH)	4550x210x690mm

PAPIER NICHT ENTHALTEN

53921

39,00€

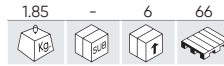

BODENROLLENHALTER



Material	Acero inoxidable/Stainless steel
Höhe	975mm
Papierrolle	380mm
Gewicht	1,85Kg
Abmessungen (LxBxH)	450x345x975mm

PAPIER NICHT ENTHALTEN

AUSZIEHBARER MEHRFUNKTIONS-GRIFF

REF.	MIN.	MAX.	KG	BOX	BOX	BOX	BOX	€
52497	1200mm	530mm	0.29	6	48	480	27,00€	
53196	1600mm	710mm	0.37	6	48	384	33,00€	



53221

5,00€



MIKROFASERTÜCHER SET - 3 TEILE



Teile	3
Farbe	Verde/Green
Material	PL
Maßnahme	360x360mm

55066

319,50€

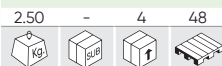

NEW

ELEKTRISCHER SCHLEIFER 150 MM 400W



Spannung	220V
Strom	400W
Frequenz	50Hz
Nominale Geschwindigkeit	4000-10000RPM
Durchmesser der Scheibe	150mm
Schleiforbit	5mm
Länge des Kabels	3m
Gewicht	1,10Kg
Abmessungen (LxBxH)	310x150x110mm

54556

74,00€

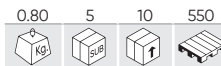

BANDSCHLEIFMASCHINE 3/8"



ERSATZTEILE VERFÜGBAR



Lufteinlass	1/4"
Nominale Geschwindigkeit	18000RPM
Tatsächlicher Luftverbrauch	113L/min
Arbeitsdruck	6,2BAR
Schallintensität	89dB
Schleiforbit	10x330mm
Schleiforbit	60x80x120mm
Winkel	90°
Gewicht	0,75Kg
Abmessungen (LxBxH)	290x100x50mm

55025

120,00€

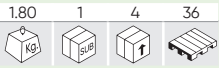

NEW

ELEKTRISCHE TROCKNUNGSPISTOLE



Spannung	220V ~ 50Hz
Strom	1350W
Länge des Kabels	5M
Luftdurchsatz	93 CFM
Maximale Luftbeschleunigung	22000ft/min
Gewicht	1,80Kg
Abmessungen (LxBxH)	270x140x280mm

60071

140,00€

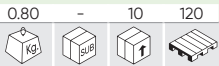

NEW

AKKUBETRIEBENER LUFTGEBLÄSE ZUM TROCKNEN VON FAHRZEUGEN



Spannung	20V
Luftstrom	55m/s
RPM (Umdrehungen pro Minute)	22500-35000
Luftdurchsatz	10,4CFM (294L/min)
Durchmesser	2,5"
Kompatibel mit	60013, 60015
Gewicht	0,76Kg
Abmessungen (LxBxH)	168x116x255mm

54771

279,00€



20L POLSTERSAUGER (TROCKEN+NASS)



ERSATZTEILE VERFÜGBAR

Spannung	230V
Strom	1200W
Frequenz	50Hz
Kapazität	20L
Liter Saugleistung pro Sekunde	26L/s
Schallintensität	82dB
Saugkraft	17-18KPa
IP-Schutz	4
Abmessungen (LxBxH)	390x340x460mm
Gewicht	7,60Kg



53947 149,00€

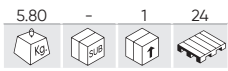

WASSERSTRAHL HOCHDRUCKREINIGUNG 1400W



ERSATZTEILE VERFÜGBAR



Spannung	230V
Strom	1400W
Frequenz	50Hz
Arbeitsdruck	70-105BAR
Maximale Durchflussmenge / Maximaler Betriebsfluss	5,5-6,8L/min
Arbeitstemperatur	50°C
IP-Schutz	IPX5
Gewicht	5,80Kg
Abmessungen (LxBxH)	280x255x440mm



53948 324,00€



WASSERSTRAHL HOCHDRUCKREINIGUNG 2400W



ERSATZTEILE VERFÜGBAR



Spannung	230V
Strom	2400W
Frequenz	50Hz
Arbeitsdruck	120-180BAR
Maximale Durchflussmenge / Maximaler Betriebsfluss	5,5-8L/min
Arbeitstemperatur	50°C
IP-Schutz	IPX5
Gewicht	12,10Kg
Abmessungen (LxBxH)	440x345x505mm



54805 478,00€

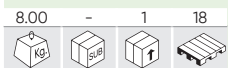

NEW

SATZ SECHSECKIGER LED-DECKENLEUCHTEN

Helligkeit	83640Lm
Strom	615W
Effizienz	110-120Lm/W
Spannung	185-240V
LED-Typ	2835
Anzahl der LED's	12
LED-Farbtemperatur	6500k
Material	Al + PC
Länge des Kabels	1,5m Enchufe europeo/ EU Plug
IP-Schutz	IP45
Gewicht	7,50Kg
Abmessungen (LxBxH)	2435x42x4845mm

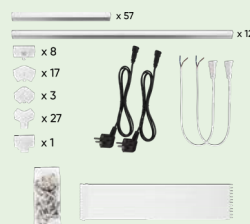

ERSATZTEILE VERFÜGBAR

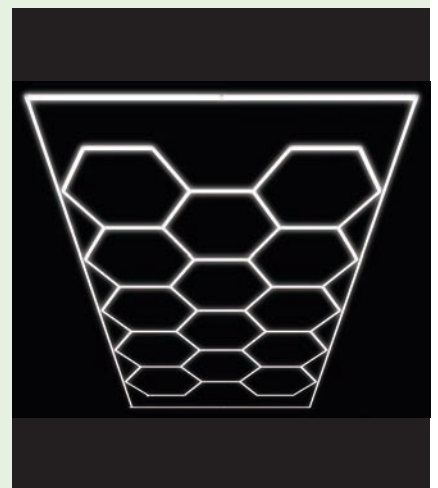



54346 12,80€

0.30 6 36 144

3ER SET REINIGUNGSBÜRSTEN FÜR BOHRMASCHINEN



Teile	3
Achsengröße	1/4"
Durchmesser	50, 88, 100mm

54912 7,90€

0.21 10 80 640

NEW

PROFESSIONELLES 4-IN-1 AUTOWASCHSET FÜR INNEN UND AUßEN



Teile	4
Material	PP
Pinsellänge	220, 225, 230, 240mm
Gewicht	0,21Kg

54895 16,80€

0.35 10 40 160

NEW

AUTO-DETAILING-SET MIT 7 WICHTIGEN ZUBEHÖRTEILEN



Teile	7
Material	PP
Pinsellänge	220, 225, 230, 240mm
Kopfdurchmesser	50, 88, 100mm
Achsengröße	1/4"
Gewicht	0,35Kg

50844 65,00€

3.50 - 1 60

STAHLHOCKER



Material	Acero/Steel, PVC
Kapazität	115Kg
Höhe	380mm
Gewicht	3,50Kg
Abmessungen (LxBxH)	360x375x380mm

54682 54,00€

1.70 - 10 40

MOBILER KNIESCHUTZ



Material	Polipropileno/Polypropylene
Maximale Belastung	100Kg
Gewicht	1,7Kg
Abmessungen (LxBxH)	500x255x85mm

53191 14,80€

0.15 - 5 160

EVA-SCHAUM UNTERLAGE



Material	Espuma EVA/EVA foam
Gewicht	0,15Kg
Abmessungen (LxBxH)	480x180x320mm